



Fair competition
for greater good

The Quarterly Newsletter of Competition Commission of India (CCI)

Fair Play

VOLUME 31 : October-December 2019

IN FOCUS

**Fifth Roadshow on
Competition Law
held in Mumbai**



Dr. M.S. Sahoo, Chairperson, Insolvency and Bankruptcy Board of India
delivering the Chief Guest's address at the Mumbai Roadshow

CONTENT...



3

From The Desk of the Chairperson



5

In Focus



22

Developments In Other Jurisdictions



8

Cartels



25

Advocacy Initiatives



9

Abuse of Dominance



27

New Initiatives- Green Channel



10

Mergers and Acquisitions



28

'Rajbhasha Puraskar at CCI



13

Judicial Pronouncements



29

Capacity Building Events



16

Eco Watch



31

HR Corner



17

Know Your Competition Law



31

Forthcoming Events



18

Engaging with The World

Find us on our Social media accounts



Facebook: [https://www.facebook.com/pages/category/Government Organization/ Competition-Commission-of-India-529934074122118/](https://www.facebook.com/pages/category/Government+Organization/Competition-Commission-of-India-529934074122118/)



Linkedin: <http://in.linkedin.com/company/Competition-Commission-of-India>



Twitter: http://twitter.com/CCI_India

FROM THE DESK OF THE CHAIRPERSON



It gives me immense pleasure to share with you the developments in the area of competition law and policy that have taken place during the last quarter of 2019 through this 31st Volume of 'Fair Play'. In this quarter, the Commission imposed penalties in its first ever international cartel case involving Original Equipment Suppliers. The cartel was detected due to leniency applications filed by the cartel members. Accordingly, the Commission decided to grant the benefit of reduction in penalty to the leniency applicants. The Commission also passed a prima facie order in the case of Odisha State Civil Supplies Corporation Ltd. wherein unfair conditions were being imposed on the Informant.

On the combinations front, the Commission received its first case filed under the Green Channel i.e. the scheme for automatic approval of combinations. The transaction pertained to the acquisition by an entity forming part of the Sachin Bansal Group, of Essel Mutual Fund. Furthermore, the combination was filed under the Green Channel route as the parties did not have any horizontal overlaps, vertical overlaps or complementary relationships. In another combination that involved a consortium of acquirers purchasing a majority stake in GMR Airports Limited, the Commission identified some concerns regarding vertical foreclosure which were addressed through appropriate voluntary modifications.

In the last quarter, yet another decision confirming the recommendatory nature of the DG Report was pronounced by the Hon'ble Delhi High Court. Furthermore, the Hon'ble NCLAT upheld the directions given by the CCI in an

earlier case pertaining to SALPG for abuse of dominant position for terminalling services at Visakhapatnam Port.

Taking forward the growing cooperation between global antitrust regulators when it comes to discussing best practices in procedural and substantive matters, the CCI held its second EU-India Competition Week which featured engaging deliberations on various matters, ranging from digital markets, Big Data, procedural fairness and transparency in Antitrust and Merger investigations, Leniency Programmes and Settlements. Such engagements reinforce the similarity of challenges faced by regulators across the globe and facilitate exchange of ideas and thoughts on ways to deal with them.

Additionally, this volume of Fair Play includes competition law developments in other jurisdictions, engagements of the Commission with global antitrust community, advocacy events, capacity building initiatives and forthcoming events.

The Commission is committed to foster healthy competition culture in the various sectors of the economy through robust enforcement and effective advocacy. Fair Play helps our stakeholders keep informed about latest developments in competition ecosystem in India and abroad and we will continue our efforts to enrich its content for the benefit of its readers.



(Ashok Kumar Gupta)



(MUMBAI ROADSHOW)



Shri Ashok Kumar Gupta (Chairperson, CCI) delivers his address to the audience at the Mumbai Roadshow

Continuing with the advocacy initiative of roadshows that was conceptualised by the Commission in FY 2018-19, the roadshow on competition law was organised on 30.11.2019 at Hotel St. Regis in Mumbai with a thematic focus on the media and broadcasting sector. The roadshow was attended by senior policy makers from Central Government, participants from the industry, legal and finance professionals, corporate lawyers, academia, among other stakeholders.

The roadshow opened with Shri Ajit Ranade, Economist (Aditya Birla Group) congratulating the Competition Commission of India (CCI) for completing 10 years of enforcement since the notification of the substantive provisions. He stressed that

this journey has not just helped enforce competition law, but also initiated a competition culture in the country. Speaking on behalf of CII (Confederation of Indian Industry), Shri Ranade observed that the CII feels closely connected to competition law and its functioning because it believes that the pre-requisite for economic development and prosperity is actually a competitive environment which has to be fair and healthy.

In his address, Shri Deepak Jacob, Chief Legal Counsel (for South East Asia, India and Middle East) for the Walt Disney Company mentioned how antitrust law is not about protecting competing businesses from each other, but instead about preserving the process of competition itself on behalf of the public. He was of the firm view that the industry



Shri. Deepak Jacob, (Chief Legal Counsel for Walt Disney) delivering his address at the opening session of the Roadshow

should not view its engagement with the CCI as adversarial in nature, but more as a partner in enabling the growth of competitive markets. Shri Jacob also shared his valuable insights into the future of the media and entertainment industry.

Shri Ashok Kumar Gupta, Chairperson, Competition



The panel of the first open house session on issues related to agreements, cartels and leniency

Commission of India stressed on the importance for any regulator, more so for a market regulator, to have a healthy dialogue with the stakeholders so as to have an enhanced vision of the market realities and a better outreach. The Chairperson elaborated that with the aim to bring important stakeholders under one roof and have open discussions with them on competition issues in order to get their perspective and experiences, the concept of roadshow was introduced last year. It was observed by him that the Commission recently completed its first decade of enforcement during which the CCI has strived to nurture a culture of competition in the market through credible antitrust enforcement and regular engagement with stakeholders. He highlighted that the enforcement of the Act is continuously evolving to dovetail the efforts of the Government to liberalise the Indian economy and bring it at par with the best economies of the world in this era of globalisation.

The Chief Guest of the event, Dr. M.S. Sahoo, Chairperson, Insolvency and Bankruptcy Board of India (IBBI), started off by

remarking that competition is important due to the manifold benefits it presents to consumers in terms of choice, quality and price. It also benefits the economy in terms of the productivity, growth and wealth creation and benefits the society in terms of innovation and welfare impact.

Dr. Sahoo outlined how competition and innovation are twin drivers of growth in a market economy. He cited the World Economic Forum (WEF) report called 'Global Competitiveness Report' while assessing competitiveness of economies. Dr. Sahoo highlighted 3 freedoms that were critical to doing business. Firstly, 'freedom of entry' at the start of the business; secondly, the 'freedom of free and fair competition' while continuing the business; and thirdly, the 'freedom to exit' when deciding to discontinue the business.

Another piece of data that was provided was that the average life of S&P 500 companies has reduced from 90 years in 1919 to 18 years in 2019. Whereas during this same time, the average lifespan of a human

being has gone up from 30 years in 1919 to over 70 years in 2019. Therefore, unlike earlier times, where the companies created would outlast their creators; present day companies have a much shorter lifespan.

Deliberations in the roadshow were divided in three open-house sessions. The first session focused on the topic of agreements/cartels/leniency and was chaired by Ms. Sangeeta Verma, Member CCI. Members of the panel discussed how to confront complex arrangements seen in new-age markets and how sufficient the framework of the Act is to tackle these issues.

The second open-house session on the merger control regime was chaired by Shri Ashok Kumar Gupta, Chairperson, CCI, and touched upon the recently launched fast-track 'green channel' route for approval of combinations as well as minority investments. It was underscored by panellists as to how the green channel route was more relevant for financial services sector or private equity players where overlaps usually do not exist.



The panel of the second open house session on green channel fast track route and minority investments

Furthermore, it was announced that CCI was in the process of coming out with a guidance note for the industry to better understand the green channel notification.

The final open-house session saw a discussion on the media and broadcasting sector. Panellists discussed; how CCI has dealt with various cases from the sector and that the key take away has been that

CCI has been extremely pragmatic in terms of the relevant market definition. It was also discussed; how the advent of technology and an increase in the penetration of the Internet has led to a profound change in how content is being consumed by viewers. Traditionally, broadcasters were ruling the market, but now there is significant competition from online streaming platforms

(OTTs). These OTTs have impacted the market in the following ways: (i) They have introduced significant amount of competition in content acquisition, (ii) challenges in distribution mode: what was previously the forte of DTH operators (due to their last mile connectivity) has been challenged by OTTs. This has forced the broadcasters to innovate.



The panel of the third open house session on competition issues in the media and broadcasting sector



Suo Motu case regarding Cartelisation in supply of Electric Power Steering Systems (EPS Systems)

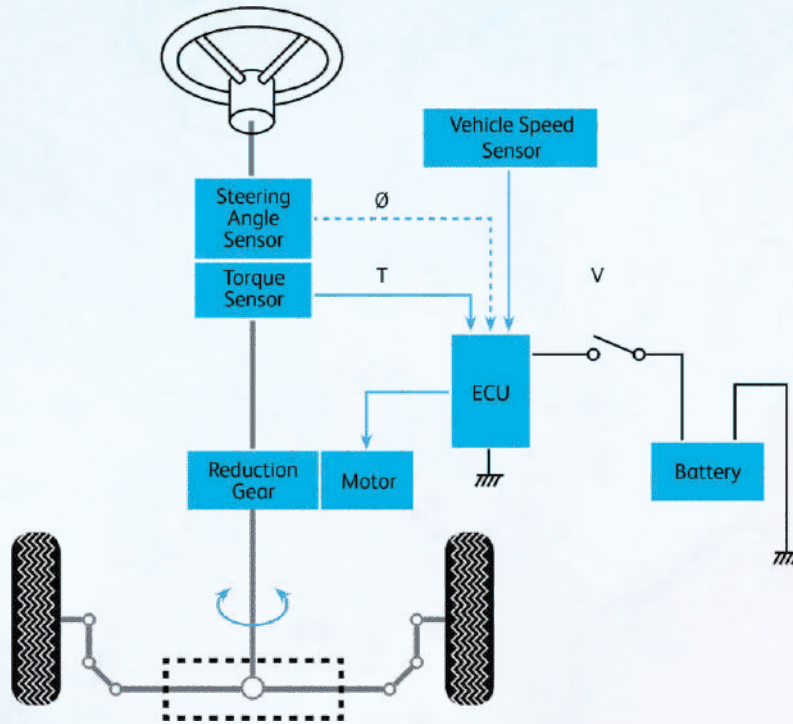

Allegation and Finding: The Competition Commission of India ('Commission'), vide its order dated 09.08.2019 passed under Section 27 of the Act, had found contravention of the provisions of Section 3(3)(a), 3(3)(c) and 3(3)(d) read with Section 3(1) of the Act by NSK Limited, Japan and JTEKT Corporation, Japan and their Indian subsidiaries namely, Rane NSK Steering Systems Ltd. (RNSS) and JTEKT Sona Automotive India Limited (JSAI) respectively. The Commission also found 8 individuals of NSK and 7 individuals of JTEKT liable in terms of Section 48 of the Act for the conduct of their respective companies and

imposed penalties on them. However, in view of the fact that lesser penalty applications under Section 46 of the Act had been filed by NSK and JTEKT, 100% reduction in penalty amounts was granted to NSK and its individuals and 50% reduction in penalty amounts was granted to JTEKT and its individuals.

Since the DG Report could not be served upon 4 individuals of NSK who were former employees of NSK before the final hearing in the matter, the DG Report was served to these individuals at a later stage upon receiving their contact details from NSK. Thus, the Commission passed a separate

order dated 20.11.2019 on these 4 individuals.

Direction: The Commission, in the subsequent order found these 4 individuals of NSK being in-charge of and responsible to NSK for the conduct of its business during the time when cartelisation was committed, guilty of contravention of the provisions of the Act in terms of Section 48(1) of the Act. Accordingly, they were directed to desist in future from indulging in any act of cartelisation, in the EPS Systems market in India. Further, in parity with the penalty imposed upon other erring individuals of NSK and JTEKT vide order 09.08.2019, the Commission decided to impose penalty upon these 4 ex-employees of NSK as well, @ 10% of the average of their incomes for the financial years 2009-10, 2010-11 and 2011-12. However, on the principle of parity again, as requested by these individuals, the Commission decided to grant benefit to them, of reduction in penalty of 100% (percent) in terms of Regulation 4(a) of the Competition Commission of India (Lesser Penalty) Regulations, 2009, as has been granted to other erring individuals of NSK, vide order dated 09.08.2019, passed in the matter.



ABUSE OF DOMINANCE



Allegation: An Information was filed by *M/s. Maa Metakani Rice Industries*, a partnership firm, against the State of Odisha represented through Commissioner-cum-Secretary, Food Supply & Consumer Welfare Department (FS & CW Department), Government of Odisha and Odisha State Civil Supplies Corporation Ltd. (OSCSCCL) alleging

contravention of the relevant provisions of Section 4 of the Act. The Informant alleged, inter alia, that the conduct of OSCSCCL was arbitrary and imposed unfair conditions on the Informant and other custom millers in the State of Odisha.

Finding: The Commission, vide, its order dated 01.11.2019, passed under Section 26(1) of the Act formed

the view that the non-settlement of Custom Milled Rice (CMR) dues of the Informant and imposition of conditions on the custom millers for entering into agreement for custom milling by OSCSCCL, prima facie attracts the provisions of Section 4 of the Act requiring investigation. Accordingly, it directed the Director General to cause an investigation into the matter.



MERGERS AND ACQUISITIONS



Commission approves acquisition of up to 55.2% of the total equity shareholding of GMR Airports Limited (GAL) jointly by TRIL Urban Transport Private Limited (TUTPL), Valkyrie Investment Pte Limited (Valkyrie) and Solis Capital (Singapore) Pte. Limited (Solis).



GAL, a public limited company of the GMR Group, is engaged in developing, managing and operating airports in India and around the world. GAL, through its subsidiaries, currently operates and manages two airports, i.e.

Delhi airport and Hyderabad airport and is developing Greenfield airports in Goa and Bhogapuram in Andhra Pradesh, and will develop and operate Nagpur airport on Public Private Partnership basis.

Following this combination, GAL will sell up to 55.2% of its stake to three Acquirers namely TUTPL, Valkyrie and Solis, who will acquire up to 24.5%, 18.4% and 12.3% respectively.

The Commission noted that Valkyrie and Solis, either directly or indirectly, exhibited no horizontal or vertical overlaps with the activities in which GAL is engaged. TUTPL, directly or indirectly, did not have any horizontal overlap with GAL but exhibited vertical overlaps.

TUTPL is a wholly owned indirect subsidiary of Tata Sons Private Limited (Tata Sons). Tata Sons is engaged in the business

of providing airline services through Vistara and Air Asia, and other associated businesses. GAL through its entities is present in the provision of upstream business segment of development, operation and maintenance of the airport. These services provided by GAL are in vertical relationship with services provided by the entities of Tata Sons group, namely, provision of scheduled air transport service, non-scheduled air transport service, food and beverage services, retail services, in-flight catering services, ground handling services, cargo services and MRO services.

It was observed that vertical relationship between Tata Sons group and the GMR group, may lead to a scenario of conflict of interest, as with vertical integration, there may be an

incentive to foreclose downstream players, i.e., the competing airlines, among other service providers.

The Commission noted that in several countries there are restrictions placed on holdings by airlines (directly or indirectly) in an airport operating company in order to avoid possible conflict of interest situation and thereby preventing likely foreclosure of the downstream players i.e. competing airlines and other service providers. Furthermore, presence of airlines in airport operating companies may have distortionary effects on competition among the airlines as such vertically integrated entity may influence and/or discriminate in favour of its entities for various services (aeronautical, non-aeronautical and other miscellaneous services).

Accordingly, TUTPL gave voluntary modification to alleviate any potential conflict of interest arising out of Tata Sons group acquiring stake in the target. The Commission noted that the voluntary modification would address apprehension that vertical integration between Tata Sons group and the GMR group may foreclose downstream competitors, inter alia, airline companies. The reason for having such restrictions are to ensure a level playing field for all the airlines. It is also to ensure that no airline gets a preferential treatment in the allotment of slot(s). Accordingly, the Commission approved the combination under Section 31(1) of the Act.

Commission approves Kora Master Fund LP investment in Edelweiss Securities Limited



The Commission received a notice filed by Kora Master Fund LP (Kora) in relation to investment of up to USD 75 million in Edelweiss Securities Limited (ESL) in the Edelweiss Global Investment Advisory business (EGIA Business).

Kora is a foreign portfolio investor (FPI) registered with the Securities Exchange Board of India (SEBI). Its principal activity is that of investment holding and related activities.

Edelweiss Securities Limited and other entities are collectively engaged in the EGIA Business that includes the business of asset management, wealth management, capital markets, advisory and asset reconstruction.

The Commission observed that apart from having a minority investment in some companies in India engaged in provision of loans/credit, Kora and Edelweiss Securities Limited are not engaged in any business activities relating to similar or identical or substitutable products or services. The Commission noted that in the overlapping segment, these entities have limited presence in India. Accordingly, the Commission approved the combination under Section 31(1) of the Act.

Commission received Green Channel filing for acquisition of Essel Mutual Fund by Sachin Bansal Group



The Commission received its first case filed under the Green Channel i.e. the scheme for automatic approval of combinations. The transaction pertained to the acquisition by an entity forming part of the Sachin Bansal Group of Essel Mutual Fund (Essel MF), a mutual fund registered under the SEBI (Mutual Funds) Regulations, 1996 (Mutual Fund Regulations).

Pursuant to the Proposed Combination, Sachin Bansal Group would acquire ownership and sole control over Essel Finance AMC Limited (investment manager) and Essel MF Trustee Limited (trustee) and, therefore, over Essel MF.

The proposed combination was filed under the Green Channel route as the Parties did not have any horizontal overlaps, vertical overlaps or complementary relationships.

CCI approves acquisition of Kwality Limited by Haldiram Snacks Private Limited.

The Commission received a notice jointly filed by Haldiram Snacks Private Limited (Haldiram) and Pioneer Securities Private Limited (Pioneer) in relation to acquisition of 100% of the total issued and paid-up equity share capital of Kwality Limited (Kwality), which is undergoing insolvency resolution



proceedings initiated under the Insolvency and Bankruptcy Code, 2016.

Haldiram is a private limited company and the flagship company of the Haldiram group. It is engaged in the business of manufacturing and marketing of variety of snack products also, and exports its products to various countries. Pioneer, a private limited company incorporated in India, renders services pertaining to stock and non-banking financial services. Kwaliti, a listed company incorporated in India, processes and sells milk and related dairy products.

It was observed by the Commission that the Parties are not engaged in any business activities relating to similar or identical or substitutable products or services. As far as vertical relationship is concerned, Haldiram procures Ghee (a dairy product) from Kwaliti. The said vertical relationship is not likely to cause any change

in the competition dynamics. Accordingly, the Commission concluded that the combination is not likely to have an appreciable adverse effect on competition in India.

CCI approves merger of BNP Paribas Mutual Fund and Baroda Mutual Fund



The Commission received a notice, jointly filed by BNP Paribas Asset Management India Private Limited (BNP AMC); BNP Paribas Trustee India Private Limited (BNP TC); Baroda Asset Management India Limited (BOB AMC); and Baroda Trustee India Limited (BOB TC). The notice was given in relation to the proposed merger of: (a) BOB AMC into BNP AMC such that BNP AMC will be the surviving entity; and (b) BNP TC into BOB TC such that BOB TC will be the surviving entity. BOB AMC and BOB TC are wholly owned by Bank of Baroda (BOB). Similarly, BNP AMC and BNP TC are wholly owned by BNP Paribas Asset Management Asia Ltd.

(BNP AM Asia).

The BOB entities and BNP entities offer Mutual Fund products in India. BOB has shareholding in UTI Asset Management Company Limited (UTI AMC) and UTI Trustee Company Private Limited (UTI TC). UTI AMC and UTI TC are also engaged in Mutual Fund business, in India. Besides mutual funds, both BNP AMC and UTI AMC are further engaged in the business of portfolio management service (PMS).

Activities of the Parties and their affiliates were found similar/identical in the domain of provision of mutual funds and PMS. The mutual fund business of the parties and distribution activities of affiliates of BNP Group and BOB exhibited vertical overlap. However, the incremental market shares, as results of the combination, in the mutual funds and PMS businesses were not significant. Similarly, the market shares of affiliates of BNP Group and BOB in distribution of mutual funds in India was not significant. Accordingly, the Commission approved the combination under Section 31(1) of the Act.



JUDICIAL PRONOUNCEMENTS



1. Hon'ble Delhi High Court upholds the Commission's decision to levy interest on delay in depositing penalty imposed

The Commission, vide Order dated 10.07.2015 had penalised Public Sector Insurance Companies, viz. National Insurance Company Ltd., New India Assurance Co. Ltd., Oriental Insurance Company Ltd. and United India Insurance Co. Ltd., under Section 27 of the Act, as they were found to have rigged the tender floated by the Government of Kerala for selecting insurance service provider for Rashtriya Swasthya Bima Yojna.

In an appeal filed by the said companies, the Hon'ble

COMPAT while upholding the Order of the Commission, reduced the quantum of penalties levied on the said companies. These penalties were deposited by the insurance companies in the Consolidated Fund of India. The Commission sought interest on delayed deposit of penalty in terms of regulation 5 of the Competition Commission of India (Manner of Recovery of Monetary Penalty) Regulation 2011, which was deposited by the aforementioned companies except United India Insurance Company Ltd., which challenged the demand for interest, by filing Writ Petition before the Hon'ble High Court of Delhi. The Hon'ble High Court vide judgment dated 11.09.2019 dismissed the writ

petition, holding that the company is liable to pay interest and it cannot take the plea that there is no liability to pay interest for the period its appeal was pending before the Hon'ble COMPAT as the appeal was dismissed by the Tribunal, eventually.

Against the judgment of the Hon'ble High Court, an appeal has been preferred before the Hon'ble Division Bench of the Delhi High Court, which is pending consideration. In the meantime, the said insurance company deposited the interest amount to Rs. 32,76,000/- with the Consolidated Fund of India on 20.12.2019, as the Hon'ble Division Bench has not stayed the judgment of the Hon'ble Single Judge.

2. Complaint filed u/s 42(3) for non-payment of penalty u/s 43 held to be maintainable:

Competition Commission of India issued notices to Rajasthan Cylinders & Containers Ltd. and Shri Jose C. Mundadan in three separate cases, however, both of them failed to comply with the said notices. Pursuant to the same, penalties were imposed upon them. Failure to deposit the penalties as imposed by the CCI under Section 43 of the Act upon Rajasthan Cylinders & Containers Ltd. and Shri Jose C. Mundadan led to initiation of criminal prosecution against them under Section 42(3) before the CMM. Same were challenged before the Delhi High Court on the grounds that Section 42(3) cannot be invoked for non-payment of penalty imposed under Section 43 of the Act and that criminal action under Section 42(3) in cases wherein penalty has been imposed under Section 43 of the Act, would lead to double jeopardy.

Upon challenge, Hon'ble Delhi High Court vide common judgment dated 29.03.2019 dismissed the said applications holding the criminal proceedings to be maintainable. The Court, while interpreting the provisions of Section 42(3) of the Act, held that the use of comma (,) in Section 42(3), with a purpose, indicates that a cause of action for criminal complaint to be filed in the court of CMM arises in two possible situations, viz., (i) there has been a failure on the part of a person to "comply with the orders or directions" issued to him under the law or (ii) on account of failure to pay fine imposed for non-compliance with orders or directions of the

CCI under specified provisions (i.e., Sections 27, 28, 31, 32, 33, 42A and 43A). Further, the court held that may be the marginal heading of Section 42 refers to contravention of orders of the Commission but, noticeably, only the first two sub-sections of Section 42 refer to "the Commission", such words being conspicuously missing in sub-section (3), the clause which provides for the offence. Thus, Section 42(3) has to be given wider connotation as the legislature clearly intended to cover the failure to comply with the "orders or directions issued", irrespective of whether they had been issued by the Commission or by its functionaries, like DG. Also, while rejecting the plea of double jeopardy, the court held that the penalty under Section 43 as imposed by CCI in exercise of its powers, is civil in nature and the criminal complaint alleging offence under Section 42(3) is an additional element of failure to comply further with the said direction.

Hon'ble Supreme Court by judgment dated 19.11.2019 in M/s Rajasthan Cylinders & Containers Ltd. vs. CCI dismissed the SLPs filed against the common judgment dated 29.03.2019 of Hon'ble Delhi High Court and held that the proceedings initiated before the Chief Metropolitan Magistrate for the non-payment of penalty levied under Section 42(3) of the Act are maintainable. The Apex Court did not find any ground warranting interference with the impugned order(s) in exercise of its jurisdiction under Article 136 of the Constitution of India.

3. DG Report is merely recommendatory and CCI is not bound by the same:

CCI ordered investigation against Great Eastern Energy

Corporation Ltd. (GEECL) upon the allegations of having violated the provisions of Section 4 of the Act by imposing unfair and discriminatory conditions for supply of Coalbed Methane Gas (CBM) in terms of the Gas Sale Purchase Agreement (GSPA). Upon investigation, DG found that certain clauses of the GSPA were in contravention of the provisions of Section 4 of the Act. Despite the DG reporting contravention, CCI closed the case against GEECL finding no case of contravention of the provisions of Section 4 of the Act. The said order of CCI was challenged before the Hon'ble Delhi High Court on the grounds that the CCI ought to direct for further inquiry rather than closing the case and that the same is contrary to the scheme of Sections 26 and 27 of the Act.

Hon'ble Delhi High Court vide judgment dated 10.10.2019 in Shri Saurabh Tripathy vs. CCI & Anr. dismissed the said petition with costs of Rs. 50,000/- to be paid to both CCI and GEECL. The Court held that if the contention that it is mandatory for CCI to direct further investigation in the event it disagrees with the DG's recommendation is accepted, it would imply that CCI can never disagree with the report submitted by the DG. This, clearly, is not the scheme of Sections 26 and 27 of the Act. The report submitted by the DG under Section 26(3) of the Act is merely recommendatory. CCI is required to examine the same and take a view after hearing the concerned parties. The provisions of further investigation/inquiry, as contemplated under sub-sections (7) and (8) of Section 26 of the Act, are only enabling provisions which enable CCI to



direct further investigation or conduct further inquiry if it is of the opinion that such further inquiry is necessary. If CCI is of the opinion that no further inquiry is necessary, it is required to form an opinion after hearing the concerned parties. If in its opinion the provisions of Sections 3 and 4 of the Act have not been violated, CCI must close the case. However, if in its opinion such contraventions have been established, it may pass any or all of the orders under Section 27 of the Act.

4. NCLAT upheld the final order passed by CCI:

Pursuant to the information filed by East India Petroleum Pvt. Ltd. (EIPL), CCI ordered investigation into alleged contravention of the provisions of Section 4 of the Act by South Asia LPG Co. Pvt. Ltd. (SALPG) on three counts: a)

while allowing the use of blender, SALPG insisted on mandatory use of cavern; b) same resulted into charging exorbitant bypass; and c) allowing 25% of the total volume (pre-mixed LPG) to be bypassed for tank truck loading while remaining gas has to be necessarily passed through the cavern of SALPG. The case concerned access to terminalling infrastructure (services that involves receipt, storage and dispatch of Propane/Butane/LPG to oil marketing companies) operated by SALPG at Visakhapatnam Port.

CCI imposed penalty of Rs. 19.07 crore on SALPG for abuse of dominant position for terminalling services at Visakhapatnam Port alongwith the directions. Aggrieved by the same, two separate appeals were filed:-i) by SALPG,

disputing the relevant geographic market, penalty imposed and non-impleadment of Hindustan Petroleum Corp. Ltd. (HPCL) and ii) by HPCL, disputing the jurisdiction of the CCI, non-impleadment of HPCL and issue of dominance.

Hon'ble NCLAT vide common judgment dated 18.12.2019 in South Asia LPG Company (P) Ltd. vs. CCI & Anr. dismissed the appeals filed by SALPG and HPCL in absence of any merit and with a direction to comply with the direction of the CCI immediately. Hon'ble NCLAT found CCI correct in holding that: i) protection of commercial interest by a dominant enterprise, at the cost of competition, is contrary to its responsibility cast under the Act; ii) effective competition does not necessarily mean prevalence of the most efficient to the exclusion of relatively less efficient choices to consumers; iii) the conduct of 'SALPG' requiring users to necessarily use the cavern and pay higher charges amounts to an unfair imposition in provision of terminalling services; and is likely to discourage imports and restrict the services otherwise offered by the EIPL; iv) impugned restriction on bypass of the cavern facility were found to be in contravention of Section 4 of the Act; and v) the bypass restrictions were found to have restricted the business volumes of 'EIPL' (Informant), was unreasonable, which denied the market access, in contravention of the provisions of Section 4 of the Act.



Bharat Petroleum Corporation Ltd. Strategic Disinvestment and Competition

Recently, the Government of India has given an in-principle approval for the strategic disinvestment of the government shareholding in five central public sector enterprises (CPSEs). It also includes the country's second-largest state refiner Bharat Petroleum Corporation Ltd. (BPCL) which is an integrated oil company in the sector. The recent move to sell 53.29% stake in BPCL is guided by the motive to tap economic potential in the sector. The basic idea is to create a robust and competitive market.

Disinvestment, which is a product of economic reforms initiated in 1991, has been adopted by the government of India as a route for privatisation. It is an area of economic policy making with multiple objectives. The most important objective is increasing efficiencies, creating new practices of corporate governance and ensuring competition in the markets. The process strives to inject market discipline in public sector units' decision making and further seeks to restructure the country's portfolio of public capital assets. The policy of disinvestment in India has evolved over the years, based on the economic and market compulsions. These compulsions have also affected the objectives and choice of disinvestment methods applied in the policy. During its initial phase, disinvestment was done mainly through sale of minority shareholding. Later, offer for sale

and strategic sale route methods were explored. For the current disinvestment policy, NITI Aayog was mandated by the government to identify CPSEs based on the criteria of (i) National Security (ii) Sovereign function at arm's length, and (iii) Market Imperfections and Public Purpose.

The current financial year has an ambitious disinvestment target. As per the disinvestment policy, the government has decided to sell a majority stake along with management control in various companies. It includes BPCL, a Maharatna CPSE, with all-India presence and robust distribution network. The divestment in BPCL is likely to fetch around 56,000 crore and is expected to attract global energy majors, such as Total SA of France and Saudi Arabia's Aramco, given that India is the world's fastest-growing major oil market. The Indian downstream market for petroleum products is almost entirely a government monopoly dominated by three largest national oil companies i.e. Indian Oil Corporation limited (IOCL), Hindustan Petroleum Corporation limited (HPCL) and Bharat Petroleum Corporation limited (BPCL). The move of the government to sell entire stake in BPCL, that holds around 23% of the market share, will lead to enhanced and effective competition. It is also important to note that divestment will unlock tremendous value by way of infusion of capital, access to advanced technologies, diversified product portfolio,

economies of scale and adoption of novel management practices in the company as well as the sector. The focus is on reaping economic potential in the sector to ensure that an optimal mix of energy resources is made available to the consumer at the right price. Moreover, the competitive market would also have positive spill over effects to the other sectors in the economy and may lead to exploration of alternative-energy source for mobility such as bio-fuels and electric vehicles.

The disinvestment process, in the downstream market, would lead to breaking of the government monopoly by the entry of the potential private player. It is essential for the success of any disinvestment policy that proactive steps are taken for creating a level playing field for public and private sector companies. New companies are expected to enter the retail market with state of the art technologies, efficient delivery systems and entrepreneurial dealer network. However, the public OMCs (oil marketing companies) may be at a disadvantage considering the restrictive guidelines, for example dealer selection criteria, applicable to them. Thus, the distortions that affect the level playing field in the market should be addressed. This will ensure a healthy mix of public-private players in the market, which will propel competitiveness and growth in the market.



KNOW YOUR COMPETITION LAW

Criminal prosecution maintainable in cases of failure to pay penalty

The Competition Act, 2002 (the Act) provides for provisions with regard to the criminal prosecution in cases of non-compliance of the orders or directions of Competition Commission of India (CCI) or upon failure to pay the fine/penalty imposed by CCI. Section 42 of the Act pertains to the steps that can be taken in case of contravention of the order of the CCI. Sub-section (1) of Section 42 of the Act provides that the CCI may cause an inquiry to be made into compliance of its orders or directions made in exercise of its powers under the Act. Sub-section (2) of Section 42 of the Act provides that in case of non-compliance, without reasonable cause, of the orders or directions of the CCI issued under Sections 27, 28, 31, 32, 33, 42A and 43A of the Act, the person shall be punishable with fine which may extend to Rs. 1 lakh for each day during which such non-compliance occurs, subject to a maximum of Rs. 10 crore, as the CCI may determine. Lastly, sub-section (3) of Section 42 of the Act provides that if any person does not comply with (i) the orders or directions issued; or (ii) fails to pay the fine imposed under sub-section (2), he shall be punished with imprisonment for a term which may extend to 3 years, or with fine may extend to Rs. 25 crore, or with both, as the Chief Metropolitan Magistrate (CMM), Delhi may deem fit. The

PENALTY!

proceedings before the CMM shall be without prejudice to any proceedings under Section 39 (Execution of orders of Commission imposing monetary penalty) of the Act.

Thus, in case a person (i) does not comply with the orders or directions issued or (ii) where applicable, fails to pay fine imposed under Section 42(2) of the Act, CCI can approach the CMM, Delhi under Section 42(3) of the Act. However, in recent past there have been instances wherein the proceedings initiated before the Court of CMM were challenged when there was failure to deposit penalty imposed under Sections which are not mentioned in Section 42 (2) of the Act.

The law with regard to the “maintainability of the criminal prosecution before the court of CMM upon failure to deposit penalty imposed under Section 43 i.e. under Section which was not mentioned in Section 42(2) of the Act” has been settled by the Hon'ble Supreme Court in *M/s. Rajasthan Cylinders & Containers Ltd. vs. Competition Commission of India*¹. Hon'ble Supreme Court held that the proceedings initiated before the

CMM for non-payment of penalty levied under Section 43 of the Act are maintainable.

The said judgment arises out of the judgment² dated 29.03.2019 of Hon'ble Delhi High Court wherein while interpreting Section 42(3) it was held that the cause of action for criminal complaint to be filed in the Court of CMM arises in two possible situations, viz., (i) there has been a failure on the part of a person to “comply with the orders or directions” issued to him under the law or (ii) on account of failure to pay fine imposed for non-compliance with orders or directions of the CCI under specified provisions (i.e., Sections 27, 28, 31, 32, 33, 42A and 43A). Thus the criminal prosecution was held to be maintainable. Further, noticing that the word 'Commission' has been conspicuously missing in Section 42(3), the clause which provides for the offence, it was held that Section 42(3) was given wider connotation as the legislature clearly intended to cover the failure to comply with the “orders or directions issued”, irrespective of whether they had been issued by the Commission or by the DG.

Endnotes

1. SLP Nos. (Crl.) 3195 & 5489 - 5490/2019

2. *M/s. Rajasthan Cylinders & Containers Ltd. v. CCI*; Crl. M.C. Nos. 4363, 5324 & 5371/2018



ENGAGING WITH THE WORLD

Participation of CCI in various workshops / seminars / meetings:

1 **Shri Ashok Kumar Gupta, Chairperson, CCI and Dr. Sanjay Kumar Pandey, Director (Law)** participated in 'OECD Competition Committee, Working Party, & Global Forum on Competition' meetings during 02.12.2019 – 06.12.2019 in Paris, France.



Shri Ashok Kumar Gupta, Chairperson (CCI) and Dr. Sanjay Kumar Pandey, Director (Law) during the OECD Competition Committee Meeting in Paris, France.



The Chairperson, CCI, addressing the Asia-Pacific competition authorities at the sidelines of the OECD Competition Committee meeting in Paris, France in December, 2019.



Dr. Sanjay Kumar Pandey (Director), presenting in the Global Forum on Competition on CCI's work at OECD meeting in Paris, France.

2 **Shri P.K. Singh, Secretary, CCI** participated in the Rabat International Conference on "Policies and Competition Law, National Experiences and International Partnership" during 13.11.2019 – 14.11.2019, in Rabat, Morocco.



Shri P.K. Singh, Secretary, CCI addressing the delegates at the Rabat International Conference held in Morocco.

3 **Shri Rajinder Kumar, Joint Director (Eco)** is participating in the Visitor Programme at Director General Competition, European Commission during 1.10.2019 to 31.12.2019, at Brussels, Belgium. The EU Visitors Programme is one of the components under the EU-India Competition Cooperation Project.

4 **Shri Ravi Kant, Joint Director General** participated in the 2019 International Competition Network (ICN) Cartel Workshop during 07.10.2019 – 10.10.2019, in Foz do Iguaçu, Brazil.

5 **Shri Arvind Kumar Anand, Deputy Director (Eco)**

participated in the Competition Commission of Mauritius' 10th Anniversary Workshop and Conference during 09.10.2019 – 10.10.2019, in Balaclava, Mauritius



Shri Arvind Kumar Anand, Deputy Director (Eco) participated in the Competition Commission of Mauritius' 10th Anniversary Workshop

6 **Dr. Sanjay Kumar Pandey, Director (Law)** participated in the OECD/AGCM (Italian Competition Authority) workshop on Abuse of Dominance during 10.10.2019 – 11.10.2019, in Rome, Italy.

7 **Ms. Pemala Lama, Deputy Director (Eco) and Shri Arpan Sharma, Deputy Director (Law)** participated in the OECD-Korea Policy Center (KPC) Competition Law Workshop on 'Competition Issues in light of Digitalisation' during 16.10.2019 – 18.10.2019, in Tokyo, Japan.



Ms. Pemala Lama, Deputy Director (Eco) and Shri Arpan Sharma, Deputy Director (Law) along with other participants at OECD-KPC workshop in Tokyo, Japan

8 **Shri Amit Tayal, Joint Director (Law)** is on secondment with the US Federal Trade Commission during 12.11.2019 – 27.12.2019, in Washington DC, USA.



Shri Rakesh Kumar, Director (Eco) attending the ICN Unilateral Conduct Workshop at Mexico City

9 **Shri Rakesh Kumar, Director (Eco) and Shri K.P. Anand, Deputy Director (Law)** participated in International Competition Network (ICN) Unilateral Conduct Workshop 2019 during 14.11.2019 – 15.11.2019, in Mexico City, Mexico.



Shri K.P. Anand Deputy Director (Law) attending a session at the ICN Unilateral Conduct Workshop at Mexico City

10 **Ms. Christine Wilson, Commissioner, United States Federal Trade Commission (USFTC)** called on **Shri Ashok Kumar Gupta, Chairperson, CCI** at CCI Office, New Delhi on 13.11.2019. Ms. Wilson also interacted with Commission's Members and its Officers and shared her views on antitrust enforcement in high tech industries.



Shri Ashok Kumar Gupta, Chairperson (CCI) felicitating Ms. Christine Wilson, Commissioner US FTC

11 **Mr. Jon J Nathan Counsel, Office of International Affairs, United States Federal Trade Commission (US FTC)** visited CCI on 14.11.2019 under the US-India MoU on Antitrust Cooperation.

12 Second EU-India Competition Week was organised during 09.12.2019 – 11.12.2019, at CCI office in Kidwai Nagar (East), New Delhi. Competition Week commenced with opening remarks from Shri Ashok Kumar Gupta, Chairperson, CCI and Mr Ugo Astuto, Ambassador of the European Union to India, Delegation of the European Union to India and Bhutan, New Delhi. The deliberations during the Competition Week provided



Mr. Ugo Astuto, Ambassador of the European Union to India being felicitated by Shri Ashok Kumar Gupta, Chairperson (CCI) during the 2nd EU-India Competition Week

insights on various issues related to Digital markets, Big Data, Procedural Fairness and Transparency in Antitrust and Merger Investigations, Leniency Programmes and Settlements. Ms. Sangeeta Verma, Member, CCI & Mr Dirk Van Erps, Adviser Antitrust and Cartels, DG Competition, European Commission delivered the closing remarks.



Delegates after the successful completion of the 2nd EU-India Competition Week



DEVELOPMENT IN OTHER JURISDICTIONS



AUSTRALIA

Australian Competition and Consumer Commission (ACCC) welcomes comprehensive response to Digital Platforms Inquiry

In 2018, ACCC conducted an inquiry into digital platforms and on 26.07.2019; the ACCC released its final report for the Inquiry. The Inquiry looked into the effect that digital search engines, social media platforms and other digital content aggregation platforms have on competition in media and advertising services markets. In particular, the Inquiry looked at the impact of digital platforms on the supply of news and journalistic content and the implications of this for media content creators, advertisers and consumers.

The ACCC's Inquiry is focused on the three categories of digital platforms identified in the Terms of Reference: online search engines, social media platforms and other digital content aggregation platforms. In accordance with the Terms of Reference, the Report focuses on the impact of the digital platforms on competition in the advertising and media markets and on three groups of users:

- + advertisers (the largest category of business users of the platforms)

- + media content creators
- + consumers

As per the press release on 12.11.2019, the ACCC has welcomed the Australian Government's commitment to adopting the key recommendations from its Digital Platforms Inquiry, which will help address the impact of digital platforms on Australian consumers, business and society.

The Government's immediate commitments and roadmap for reform address the ACCC's main competition and consumer priorities, including concerns about privacy and the use of data. The ACCC will continue its work in digital platform markets through the establishment of a permanent Digital Platforms Branch. This will enable continuous and consistent scrutiny of digital platforms, and current and future consumer and competition law enforcement cases. In addition, the ACCC will start a new inquiry into the digital advertising tech supply chain, focusing on digital display ads.

The Government's response includes tasking the ACCC to oversee the development of a new code that will address the inherent power imbalance between platforms and media companies in Australia.

The Government's announcement also takes steps towards ensuring news media businesses and digital platforms operate on a more equal regulatory footing, and that local journalism is supported.

ACCC findings and recommendations regarding the use of data, and privacy protections also form part of the Government's plans, which include steps to ensure consumers are adequately informed about how their data is collected, and to provide consumers with greater control over how it is used.

RUSSIA

Bid rigging cartel in the Electric Power Industry opened by Federal Antimonopoly Service (FAS)

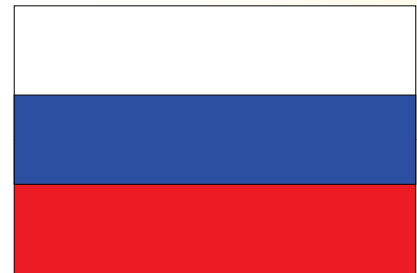

The case against "Lenelectromontazh" Ltd. and "Sevzapelectroset' montazh" Ltd. is opened based upon inspections' findings. FAS carried an unscheduled on-site inspections and exposed elements of a bid-rigging cartel for construction-and-assembly, start up and commissioning and reconstruction world in the electric power industry.

This bid rigging cartel amounted for over 20.6 billion RUB and there by resulted in a judicial inquiry primarily based upon elements of violating Clause 2 Part 1 Article 11 of the Federal Law "On Protection of Competition".

In Russia, cartel elements include jointly and illegally preparing competitors to take

part in the auctions and coordinating price bids.

Mr. Andrey Tenishev, Head of FAS Anti-Cartel Department commented, "FAS works actively to investigate cartels in regulated activities. Cartels implemented in construction of electricity network equipment must generate scrutiny, as they affect end-users and can result in an unreasonable growth of prices."

JAPAN

Japan Fair Trade Commission (JFTC) issues cease and desist orders and surcharge payment orders to dealers of activated carbon

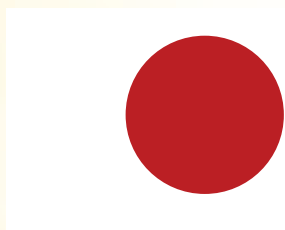

The Japan Fair Trade Commission (JFTC) issued cease and desist orders and surcharge payment orders to the following dealers:

- ✦ Who provided the specific Activated Carbon for local governments in East Japan area, and;
- ✦ Who provided the specific Granular Activated Carbon for local governments in Kinki area.

These dealers violated the Article 3 of the Antimonopoly Act. According to Article 3 of the Antimonopoly Act, An enterprise must not effect private monopolization or unreasonable restraint of trade.

The JFTC upon investigation found that these dealers

substantially restrained competition in the fields of the above specific Activated Carbon and specific Granular Activated Carbon by, in concert with one another, designating prospective suppliers and deciding that these carbons would be provided for local governments by way of Honcho Chemical Inc. The total amount of the surcharge is about 434.6 million yen.

UNITED STATES OF AMERICA

The Federal Trade Commission (FTC) amicus brief explains that relevant antitrust markets should be defined in light of the anticompetitive effects alleged

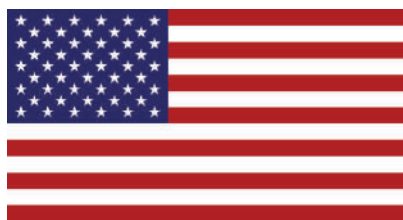

FTC has submitted an amicus brief concerning the definition of market in *Staley v. Gilead Sciences Inc.*, an antitrust case pending before the U.S. District Court for the Northern District of California (Case No. 3:19-cv-02573-EMC).

The plaintiffs allege that Gilead and three other manufacturers of branded HIV medications took various anticompetitive actions that resulted in higher prices for products known as combined antiretroviral therapy drugs. The plaintiffs' complaint alleges that at least two antitrust product markets are relevant to assessing anticompetitive effects because the challenged conduct harmed competition in multiple ways. Defendant Gilead has asked the court to dismiss the complaint, based in part on

an argument that the overlapping markets alleged are "contradictory" and therefore improper as a matter of law.

The amicus brief submitted by FTC takes no position on the underlying factual assertions or the ultimate disposition of Gilead's motion to dismiss. The FTC's brief goes on to explain the Gilead's argument on market definition is inconsistent with core legal principles governing market definition in antitrust cases. It further notes that market definition is merely a tool to help determine whether challenged conduct is likely to have anticompetitive effects.

Thus, the brief explains, when multiple types of anticompetitive harm are alleged, multiple markets may be relevant. Market definition always requires sufficient factual support, the brief observes, but defining different product markets to assess different theories of harm is neither "contradictory" nor legally deficient.

EUROPEAN UNION

Mergers: European Commission opens in-depth investigation into proposed acquisition of Metallo by Aurubis



The European Commission has opened an in-depth investigation to assess the proposed acquisition of Metallo (based in Belgium) by Aurubis (based in Germany), under the



EU Merger Regulation. The Commission is concerned that the acquisition may reduce competition in the purchasing of copper scrap for refining.

The merger would bring together the two largest purchasers and refiners of copper scrap in Europe, leading to very large combined market shares in the purchasing and refining of copper scrap.

The preliminary investigation suggests that the two companies are each other's closest competitors, in particular for the purchasing and refining of complex and tin-bearing copper scrap. For companies who supply these materials, Aurubis and Metallo could currently be the only two viable purchasers.

The initial investigation also suggests that exporting certain types of copper scrap might not be a viable alternative, as there appear to be regulatory

limits to exporting certain types of waste and as the costs of long freight as well as other factors may make export unprofitable.

Therefore, at this stage, the Commission is concerned that, following the transaction, the merged entity could hold a dominant position in the procurement of copper scrap for refining, giving it increased buyer power to negotiate lower prices for the copper scrap it purchases. By preventing competition on price, the merger could thus disrupt the normal functioning of the copper recycling industry, lowering the incentives for recyclers to collect and sort copper scrap.

The Commission will also further investigate the following issues:

- + Lower prices for copper scrap could translate into higher costs for industrial manufacturers which generate copper scrap as a by-product of their industrial production. These

manufacturers may pass on their overall increased costs to their customers, which in turn may lead to higher prices for manufactured products.

- + Aurubis is the largest producer in the European Economic Area (EEA) in the downstream markets for copper cathodes and wire rods. With the acquisition of Metallo, Aurubis could gain control over the supply of important inputs for these products. The Commission will further investigate whether the merger will increase Aurubis' incentives and ability to restrict the ability of its actual or potential rivals to compete effectively.

The Commission will now carry out an in-depth investigation into the effects of the proposed transaction to determine whether it is likely to significantly reduce effective competition.

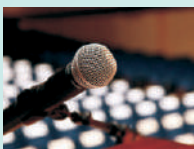

ADVOCACY INITIATIVES

1. Shri V. Sriraj, Joint Director (Law) delivered a lecture on Competition Law at SASTRA, Thanjavur, Tamil Nadu on 09.10.2019.



2. Shri Sukesh Mishra, Director (Law) and Shri Saurabh, Deputy Director (Eco) participated as Judge in a moot court competition on competition law organised by Institute of Law, Nirma University at Ahmedabad from 11.10.19 to 13.10.19.

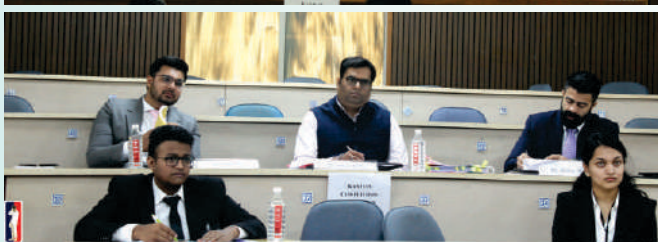

3. Ms. Payal Malik, Adviser (Eco) participated as a speaker on the topic 'Regulating the Gig Economy' during Indian School of Business (ISB)'s annual Workshop on 'Digital Transformation' on 11.10.2019, at ISB, Hyderabad Campus.

4. Shri Kuldeep Kumar, Joint Director (Law) was a Judge in the 3rd National Moot Court competition at the ULS Chandigarh University (Vaktavya) on 12.10.2019.

5. Shri Pranav Satyam, Deputy Director (Eco) delivered a lecture on Competition Law at Bennett University, Greater NOIDA (UP) on 15.10.2019.

6. Shri Rahul Ravindran, Director (Law) delivered a lecture at National Academy of Audit and Accounts, Shimla on 17.10.2019.

7. Dr. Navdeep Singh Suhag, Deputy Director (Law) delivered a lecture on Role of Competition Law at Chhotu Ram Institute of Law, Rohtak on 18.10.2019.

8. Ms. Jyotsna Yadav, Deputy Director (FA) delivered a lecture at National Institute of Financial Management at Faridabad on the topic of "Competition issues in public procurement" on 25.10.2019.



9. Shri Yogesh Dubey, Deputy Director (Eco) participated in a Panel Discussion at National University of Advanced Legal Studies (NUALS), Kochi (Kerala) on 26.10.2019.



10. Ms. Yakshi Jaisingh Chauhan, Deputy Director (Law), delivered a lecture on Competition Law at Bennett University, Greater NOIDA (UP) on 05.11.2019.

11. Shri Manish Mohan Govil, Adviser (Law) delivered a lecture on competition law at National Academy of Customs, Indirect Taxes and Narcotics, Faridabad on 07.11.2019.

12. Shri Kuldeep Kumar, Joint Director (Law) delivered a lecture on Competition Law at a seminar at Baba Mastnath University, Rohtak on 09.11.2019.



13. Shri Ved Prakash Mishra, Director (Law) delivered a lecture on “Law relating to motor accident claims and competition law” at the Himachal Pradesh Judicial Academy, Shimla on 09.11.2019.

14. Dr. K.D. Singh, Joint Director (Law) delivered a lecture on competition law at Kanoria PG Mahila Mahaviyalaya, Jaipur on 15.11.2019.

15. Dr. Bidyadhar Majhi, Director (Eco) and Shri Arpan Sharma, Deputy Director (Law) delivered a lecture on competition law at KIIT Bhubaneswar on 15.11.2019.

16. Ms. Payal Malik, Adviser (Eco) participated as speaker in Plenary session “Putting our Fears on the



Table: An Honest Assessment of Challenges posed by Online Economy and Responses Thereto” on day 2 of the 6th CUTS-CIRC Biennial Conference on “Competition, Regulation and Development” held in New Delhi on 02.12.2019.

17. Ms. Sayanti Chakrabarti, Joint Director (Eco) participated in the 6th CUTS-CIRC Biennial Conference on Competition, Regulation and Development as a discussant in the Panel on “Interface Between Competition Regime and Sector Specific Regulators in Online Economy: Challenges and Opportunities in Developing Economies” on 02.12.2019.

18. Dr. K.D. Singh, Joint Director (Law) delivered a lecture at the Mumbai NLU on 05.12.2019.

19. Ms. Payal Malik, Adviser (Eco) attended a meeting, under the Chairmanship of Shri Atul Kumar Tiwari, Additional Secretary, Ministry of Information and Broadcasting, on the issue regarding “Jurisdiction of TRAI and CCI relating to anti-competitive practices in media and broadcasting sector” held at New Delhi on 10.12.2019.

20. Shri Sukesh Mishra, Director (Law) delivered a lecture on 'Contemporary issues in competition law' at NUJS Kolkata on 13.12.2019.

21. Shri Mukul Sharma, Deputy Director (Eco) delivered a lecture on “Competition law in India” at the Gitarattan International Business School (IP University), Rohini (Delhi) on 13.12.2019.



22. Shri Rakesh Kumar, Director (Eco), delivered a lecture on competition law to at Sidho Kanho Birsha University, Purulia, West Bengal on 20.12.2019.



23. Shri Alok Tripathi, Joint Director General and Shri Pranav Satyam, Deputy Director (Eco) delivered lectures during a course on “Financial Management including Commercial Accounting, Costing & Marketing” at the National Academy of Defence Production, Nagpur on 20.12.2019.





NEW INITIATIVE

Green Channel

Regulation of mergers and acquisitions is an important function of the Commission. Not all mergers and acquisitions are regulated under the Competition Act, only those that meet the asset or turnover thresholds prescribed alone are qualified as 'combination' and are subject to competition assessment. Further, nearly 80% of the combinations are notified to the Commission in Form-I and are cleared within an average of 18 days, as they do not have any competition concern. The Competition Law Review Committee ('Committee'), constituted for reviewing the working of the Competition Act, 2002, also recommended 'green channel' for automatic approval of CCI for specific merger and acquisition cases, where there are no major concerns of an appreciable adverse effect on competition.

The Competition Commission of India in order to further facilitate fast processing of such M&A deals requiring lesser degree of

competition assessment notified the Green Channel in August 2019 by amending CCI (Procedure in regard to the transaction of Business relating to Combinations) Regulations, 2011 ('Combination Regulations'), through the gazette notification dated 13.08.2019, which permitted green channel filings from 15.08.2019.

As per the notification, those combinations that meet the criteria set out in newly introduced Schedule III of Combination Regulations, are permitted to file the combination notice along with a declaration as per Schedule IV of the said regulations with the Commission. Upon filing of a notice under said provisions and acknowledgement thereof, the combination shall be deemed to have been approved by the Commission under sub-section (1) of section 31 of the Act. This system would significantly reduce time and cost of transactions and ensure that

businesses in India are able to consolidate with minimal regulatory compliance, gain from economics of scale and compete at the global level.

Initially, the number of the transactions reported under the green channel route were less due to the inadequate awareness. The Commission revised the Pre-filing consultation guidelines to extend its scope and encourage substantive consultations for combinations including those under Green Channel. In this regard, the Commission had also written letters to various commerce and industry associations to spread awareness amongst its member entities about the pre-filing consultancy facility of the Commission.

As on date, five cases were filed with CCI under Green Channel route and the details of these Green Channel combinations are given below.

SL.No.	Green Channel Cases
1	Acquisition of the Essel Mutual Fund by an entity forming a part of the Sachin Bansal Group. (Combination Case-691)
2	Acquisition of equity stake in Hero Future Energies Global Ltd and non-voting compulsorily convertible preference shareholding in Hero Future Energies Private Ltd. by Abu Dhabi Future Energy Company P.J.S.C. – Masdar (Combination Case-699)
3	Acquisition of 100% equity shares of IDBI Asset Management Ltd., IDBI MF Trustee Company Ltd. by Muthoot Finance Ltd. (Combination Case-710)
4	Acquisition by Qatar Holding LLC of 25.1 % of the total equity share capital of Adani Electricity Mumbai Limited and of Adani Electricity Mumbai Services Limited from Adani Transmission Limited. (Combination Case-712)
5	Acquisition of shares and control of GVK Airport Holdings Limited by Green Rock B 2014 Limited, National Investment and Infrastructure Fund and Indo-Infra Inc. (Combination Case-713)



RAJBHASHA PURASKAR AT CCI

भारतीय प्रतिस्पर्धा आयोग में राजभाषा पुरस्कार वितरण समारोह

भारतीय प्रतिस्पर्धा आयोग में राजभाषा हिन्दी के प्रगामी प्रयोग को बढ़ावा देने के लिए १६ से ३० सितम्बर, २०१९ तक हिन्दी पखवाड़ा मनाया गया और इस दौरान आयोग के अधिकारियों के लिए हिन्दी निबंध, हिन्दी टिप्पण एवं आलेखन तथा हिन्दी प्रश्न मंच प्रतियोगिताएं आयोजित की गईं।

दिनांक ०५ नवम्बर २०१९ को हिन्दी पखवाड़े का समापन समारोह आयोजित किया गया। इस अवसर पर श्री पी. के. सिंह, सचिव (भा.प्र.आ.) द्वारा पुरस्कार विजेताओं को प्रमाण पत्र एवं नकद पुरस्कार प्रदान किए गए।





CAPACITY BUILDING EVENTS

I. CCI organized following two lectures under CCI's Distinguished Visitors Knowledge Sharing Series (DVKS) during the quarter:

- ✦ 28th lecture by Dr. M. S. Sahoo, Chairperson, Insolvency and Bankruptcy Board of India (IBBI) on the topic 'Building Capacity for Economic Freedom' on 25.10.2019.
- ✦ 29th lecture by Prof. Vijay Paul Sharma, Chairman, Commission for Agricultural Costs and Prices (CACP) on the topic 'Emerging Trends in Indian Agriculture: Key Policy Issues and Options' on 15.11.2019.



Dr. M.S. Sahoo, Chairperson, Insolvency and Bankruptcy Board of India delivering the DVKS lecture to CCI Officers



Prof. Vijay Paul Sharma with Shri Ashok Kumar Gupta, Chairperson (CCI), Ms. Sangeeta Verma, Member (CCI) and Shri B.S. Bishnoi, Member (CCI)

ii. CCI organized one-day Attachment Programme with CCI & O/o DG, CCI for four Indian Corporate Law Services Officer Trainees (Allotment year 2017, 9th batch, Group-2) on 17.10.2019 as a part of their Professional Course under 7-weeks On-The-Job-Training Programme.

iii. Ms. Nutan Kumari, Assistant Director (Library Services) attended 2nd International Conference on 'Equitable Access to Government Information and Data: Role of Government and Public Libraries in South Asia' organized by Central Government Library Association Delhi Branch (CGLA) in collaboration with Indira Gandhi National Centre for the Arts (IGNCA) and IFLA-Asia and Oceania & Government Library Section at IGNCA, New Delhi during 17.10.2019 – 19.10.2019.

iv. Shri Arpit Gupta, Deputy Director (Eco), Mr. Jaideep Singh, Deputy Director (Law) and Shri Anshul Jain, Deputy Director (FA) attended a residential training program on 'Corporate Intelligence' organised by Ministry of Corporate Affairs (MCA) and Indian Institute of Corporate Affairs (IICA) under MCA's Corporate Data Management Project during 30.10.2019 – 01.11.2019 at Indian Institute of Management Calcutta (IIMC).



v. Shri S. K. Tiwari, Office Manager (CS) attended a Management Development Program on 'Public Procurement' organised by National Institute of Financial Management (NIFM) during 04.11.2019 – 09.11.2019, at NIFM Campus, Faridabad.

- vi. CCI, under its Special Lecture Series (SLS) organised presentations on the following two reports with the help of Confederation of Indian Industry (CII) on 05.11.2019

- CII-Bain report titled 'India M&A Report 2019: M&A Trends and Lessons for Dealmakers' by Shri Vikram Chandrasekhar, Principal, Bain & Co., and
- CII-M&A Report titled 'India's M&A and Distressed Opportunity Landscape' by Ms. Nandini Chopra, Managing Director, Alvarez & Marsal.



Shri Vikram Chandrasekhar, Principal (Bain & Co.) presenting the CII-Bain report on M&As in India

- vii. Shri Anuj Verma, Deputy Director (FA), Ms. Pemala Lama, Deputy Director (Eco) and Ms. Bulbuli Richong, Deputy Director (Law) attended a residential training program on 'Conflict Resolution Techniques' organised by Ministry of Corporate Affairs (MCA) and Indian Institute of Corporate Affairs (IICA) under MCA's Corporate Data Management Project during 14.11.2019 – 15.11.2019, at National Law School of India University (NLSIU), Bangalore.
- viii. Shri Surender Singh, Assistant Director (CS) and Shri Sunil Kumar Bhadauria, Office Manager and Nodal Officer for RTI attended a residential workshop on 'Right to Information Act' organized by National Academy of Human Resource Development (NAHRD) during 18.11.2019 – 20.11.2019, at Goa.



- ix. CCI organized its annual team-building and leadership offsite workshop 'Pratispardha Manthan 2019-20' for professional officers during 08.11.2019 – 10.11.2019 and support officers during 30.11.2019 – 02.12.2019, at Hotel Golden Sarovar Portico, Amritsar. Dr. Umesh Kumar, Faculty HRM & OB Area, Chairperson-MBA & Executive MBA Programme, Indian Institute of Management (IIM), Amritsar was the resource person for the workshop lecture/ talk. Team-building activities were organized and conducted by M/s City on Pedals, Amritsar.



CCI Officers at the Pratispardha Manthan 2019-20

- x. Ms. Deepa Ramesh, Deputy Director (F&A) and Shri Milanjyoti Sonowal, Assistant Director (F&A) attended a conference on Internal Audit with the theme 'Raising Internal Audit's Game: Changes and Opportunities in the New Digital Age' organized by Internal Audit Standards Board of The Institute of Chartered Accountants of India (ICAI) on 22.11.2019 – 23.11.2019, at Hotel Leela Ambience, Gurugram.
- xi. Shri Nilotpal Bal, Deputy Director (Eco) attended one-day workshop on 'Preparing Cabinet Notes' on 29.11.2019, organized by The Institute of Secretariat Training and Management (ISTM) at its New Delhi campus.
- xii. Shri Manish Mohan Govil, Adviser (Law), delivered a lecture on the topic 'Merger Control' at National Law School of India University (NLSIU), Bangalore on 12.12.2019.



HR CORNER

- i) Shri Saurabh Jagati joined as Joint DG in the O/o DG, CCI on deputation basis w.e.f 01.10.2019. Shri Ravi Vazirani joined as Deputy Director (CS) w.e.f 29.11.2019 and Shri Pawan Kumar joined as PPS w.e.f 21.10.2019, in CCI on deputation basis.
- ii) Shri Ansumsan Pattnaik, Addl. DG and DG (I/c) was relieved on 28.11.2019 on completion of his deputation tenure. Shri Anand Chandra Ojha, Joint Director (Eco.) and Shri S.K. Tiwari, OM(CS) were relieved w.e.f 24.12.2019 and 02.12.2019 respectively on completion of their deputation tenure.
- iii) A vacancy circular to fill up 18 posts in CCI on deputation basis was issued on 26.11.2019. Another vacancy circular inviting applications for the post of Secretary, CCI on deputation/promotion basis was issued on 03.12.2019.
- iv) DPCs for promotions in CCI were conducted during the month of December, 2019 and promotion orders of the officers recommended by DPCs were issued.
- v) 32 candidates were selected for engagement as Research Associates in CCI and 30 of them joined.



FORTHCOMING EVENTS



- i. **One-week residential Induction Training Programme for newly joined Research Associates is planned to be organized at Indian Institute of Corporate Affairs (IICA) during the month of January 2020.**



- ii. **Appreciation Course on 'Parliamentary Processes & Procedures' for a group of CCI officers at Parliamentary Research and Training Institute for Democracies (PRIDE) is planned to be organized during 17.02.2020 – 18.02.2020.**



- iii. **The Competition Commission of India will be organising its fifth edition of National Conference on Economics of Competition Law on 06.03.2020 at India Habitat Centre, New Delhi.**



- iv. **Completion of selection process to fill up vacant posts in DG's office on deputation basis. Matter is already under consideration of Ministry of Corporate Affairs.**



- v. **Completion of selection process to fill up vacant posts in CCI on deputation basis.**



- vi. **Issue of fresh vacancy circulars on deputation basis in respect of CCI and DG's office.**



Competition Commission of India



Confederation of Indian Industry

Roadshow on Competition Law and Practice

0 November 2019

Mumbai



The Chairperson, CCI gives his views on the Green Channel automatic approval route while discussing the Indian merger control regime at the Mumbai Roadshow.

Competition Commission of India

9th Floor, Office Block-1, Kidwai Nagar (East),
New Delhi- 110023, India

Please visit www.cci.gov.in for more information about the Commission.
For any query/comment/suggestion, please write to advocacy@cci.gov.in

Follow us on:



Disclaimer: The contents of this publication do not necessarily reflect the official position of the Competition Commission of India. Contents of this newsletter are only informative in nature and not meant to substitute for professional advice. Information and views in the newsletter are fact based and incorporate necessary editing.